

REVISION RECORD			
REV	ECN	DESCRIPTION	DRFT DATE

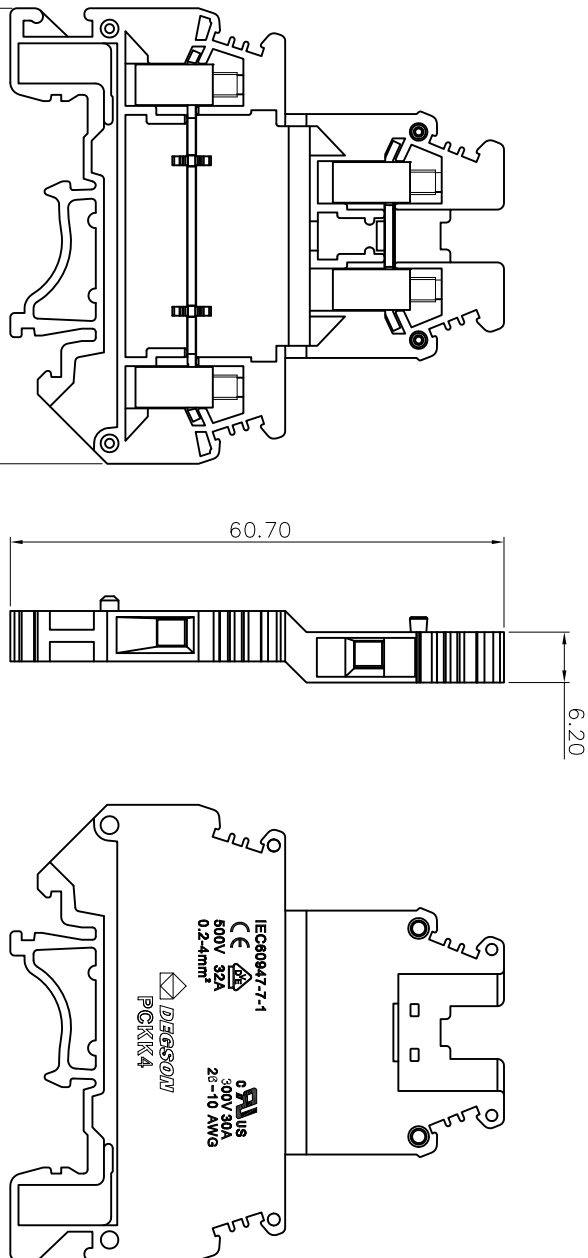

NOTES1:

UL Standard

1. Rated voltage/current : 300V / 30A
2. Withstanding voltage : AC1600V/1Min.
3. Torque value : M3, 4.43Lb.in
4. Wire range : 26~10AWG

IEC Standard

1. Pollution Degree	3
Overvoltage Category	III
Rate Impulse Voltage(KV)	6.0KV
Rate Voltage(V)	500V
Rate Current(A)	32A

2. Torque value : M3, 0.5N.m
3. Wire range : 0.2-4.0mm²

NOTES2:

1. Dimension shall be interpreted per ASME Y14.5-2009
2. Pitch : 6.20mm, Poles : N=01P
3. Stripping length : 7~8mm
4. Operating temperature: -40°C~+105°C
5. Undimensioned tolerances:

Pitch range	in	Nominal dimension	range	in	mm	mm
Over	6	10	TO	Over	30	60
TO	10	TO	TO	TO	100	150
6	10	24	30	60	100	150
F0.15;F0.20;F0.30;F0.50;F0.70;F1.00;F1.30 ±2'						

6. RoHS Compliance

PCKK4 - 01P - 1Y - 00A (H)
 (Series No.) (Poles) (Single Pitch) (Color) : 1. (Grey)
 2. (Blue)
 3. (Black)
 4. (Green)
 5. (Orange)
 6. (Red)
 7. (Transparent)
 8. (Yellow)
 9. (White)

DETACHED LISTS			
PART NO.:	/	NAME:	DEGSON® NINGBO DEGSON ELECTRICAL CO., LTD 宁波高松电子有限公司
APPD:	/	TITLE:	CUSTOMER DRAWING
CHKD:	/	DRAWING NO.:	/
DRFT:	/	REV	DO
THIRD ANGLE PROJECTION		SCALE	1:1